

Engine to Gearbox ‘marriage’

For the assembly of the Engine to Gearbox, CK has designed and manufactured a number of tooling fixtures including the one shown right, which was supplied to Ford in Russia to assist with the production of the Ford Mondeo vehicle variant.

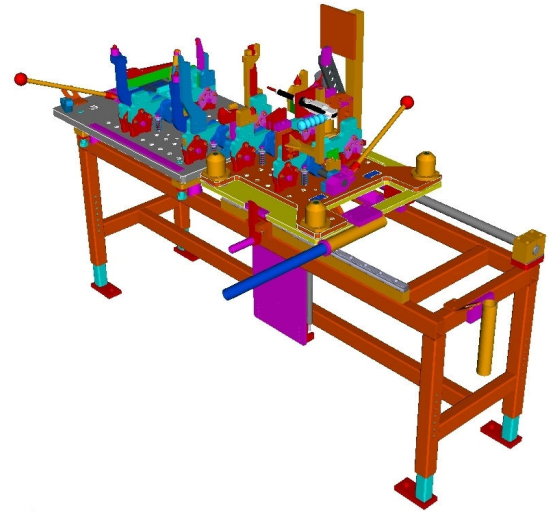

This particular unit is capable of assembling 4 different engines to 3 different gearbox types using the principal of interchangeable ‘Slave Tools’ for each combination.

Below shows an overview of the separate components used within the Auto Gearbox version

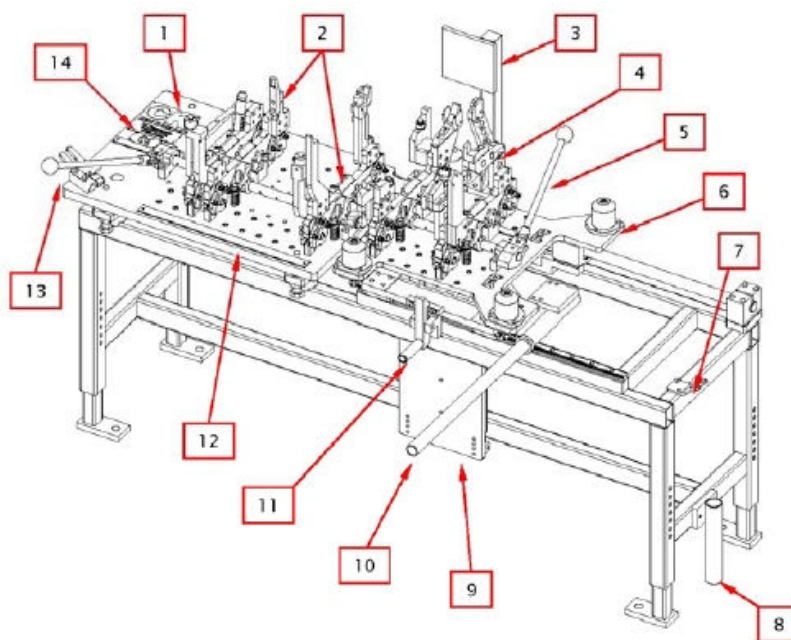

- 1 Engine Base Plate
- 2 Engine Slave Tools
- 3 Gearbox Back Plate
- 4 Gearbox Slave Tools
- 5 Slave Tool Release Handle
- 6 Gearbox Base Plate
- 7 Release Handle Rest
- 8 Lifting Handle Support
- 9 Gas Spring Mounting Plate
- 10 Lifting Handle
- 11 Latch Release Handle
- 12 “Engine” Label
- 13 Slave Tool Release Handle
- 14 CK, CE & Tool No. Labels